

SPECIFICATIONS

FARMHOUSE QUARTET

NativeStone® Collection



TOP VIEW

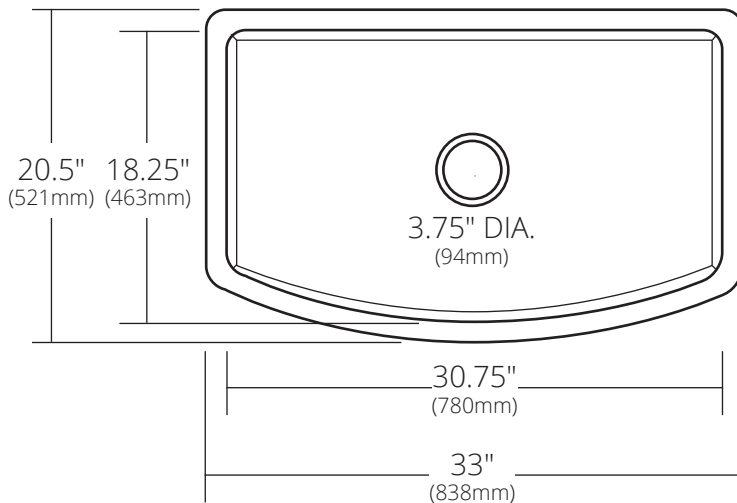

FRONT VIEW

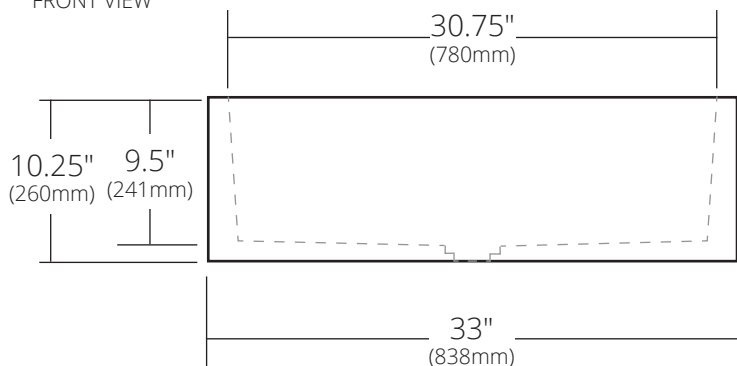

- NSKQ3320-A Ash
- NSKQ3320-S Slate
- NSKQ3320-P Pearl
- NSKQ3320-E Earth

PRODUCT DETAILS

- 33" x 20.5" x 10.25" OD (838mm x 521mm x 260mm)
- 30.75" x 18.25" x 9.5" ID (780mm x 463mm x 241mm)
- 3.75" (94mm) drain opening
- Handcrafted from sustainable NativeStone
- Sealed with NativeStone Shield

INSTALLATION

- Undermount or Apron-Front

COORDINATING PRODUCTS

- Drains: DR320 or DR340
- Bottom Grid: GR2715
- NativeStone Shield

STANDARDS COMPLIANCE

- UPC/cUPC compliant

IMPORTANT

Do NOT use tape or other adhesives on NativeStone as it may remove the sealer. Due to the handcrafted nature of this product, it will vary in finish, texture, and other details. Dimensions may vary up to ¼" (6mm). We strongly recommend waiting for the actual product before making any installation cuts.